

DEFRO[®]

heating technology

**CLASSY
BOILERS**



5th CLASS BOILERS AND ECODESIGN

www.en.defro.pl

DELTA EKOPELL | 10-30 kW



EcoDesign requirements fulfilled for all powers.

The boiler meets the requirements of the class 5 acc. to the PN-EN 303-5:2012 for all powers.

Fuel: Wood pellet with diameter 6 mm.

WARRANTY
5
YEARS

5 years warranty for heat exchanger tightness, 2 years for the remaining components and efficient operation of boiler;

STEEL

Heat exchanger made of certified high-grade steel;



90,8-95,3%

High thermal efficiency in the range from 90,8 to 95,3% due to increased heat recovery from flue gases;

APC K
SLIM

APC K SLIM ADAPTIVE CONTROL servicing four pumps /central heating, domestic hot water, floor/. Control of one mixing valve: preview and change of parameters of the main ONLINE controller - extra payable option;



Boiler adapted for installation in the closed system provided that protections were installed in accordance with the operation and maintenance manual of the boiler;

ADAPTIVE
CONTROL

ADAPTIVE CONTROL control - adjustment of boiler operation based on air flow through the heat exchanger;



Ceramic catalysts stabilising combustion process;



Fuel self-ignition system;



Pellet burner with automatic cleaning function in standard;



APC K SLIM CONTROLLER



ADAPTIVE CONTROL



DELTA EKOPELL

BOILER DIMENSIONS IN MM

Dimension	10 kW	15 kW	20 kW	25 kW	30 kW
A1/A2	124/104	124/104	124/104	124/104	124/104
B	609	609	691	691	681
C	Ø 159	Ø 159	Ø 159	Ø 159	Ø 178
D	903	903	985	985	985
E	1033	1033	1115	1115	1115
F	1354	1354	1354	1354	1354
G	1240	1240	1240	1320	1370
H	730	804	844	844	844
I	342	337	340	360	375
J	1170	1239	1282	1301	1317
K	1219	1222	1225	1223	1223
L	470	470	470	520	570
M	700	700	700	700	700

BOILER EQUIPMENT / PRODUCT TYPE C

Name	Additional equipment
APC K Slim controller	standard
ADAPTIVE CONTROL control system	standard
PID function	standard
levelling legs	standard
igniter	standard
pellet burner with automatic cleaning function	standard
GSM module	extra charge *
INTERNET module	extra charge *
WIFI INTERNET module	extra charge *
room controller DEFRO SPK Lux	extra charge *
I-1 module	extra charge *
I-1m module	extra charge *
ST-292 v3 room controller	extra charge *
ST-292 v2 room controller	extra charge *
SPK Lux wireless regulator	extra charge *
set for wireless communication RS	extra charge *

* According to the current price list.

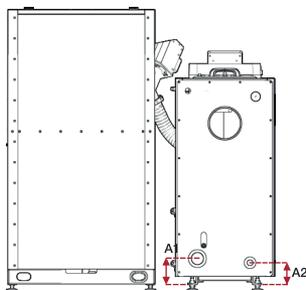
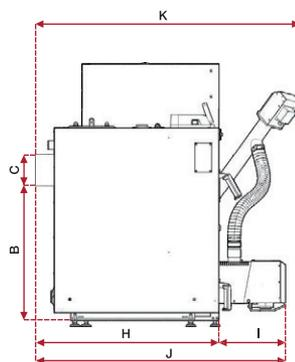
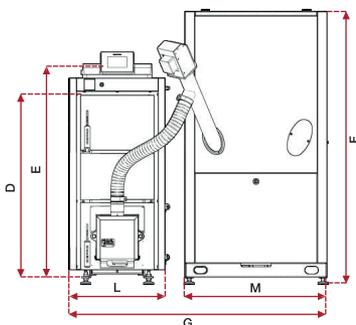

TECHNICAL DATA OF THE BOILER / PRODUCT GROUP D

Specification / boiler type	unit	10	15	20	25	30
Fuel	-	wood pellet with diameter 6 mm				
5 class according to PN-EN 303:5-2012	-	✓	✓	✓	✓	✓
Ecodesign	-	✓	✓	✓	✓	✓
Power range	kW	3,0-10	4,5-15	6,0-20	7,5-25	9,0-30
Heating area	m ²	1,8	1,9	2,2	2,5	2,7
Area of heated rooms ¹	m ²	to 130	to 180	to 210	to 250	to 330
Capacity of fuel container ²	kg	~200	~200	~200	~200	~200
Nominal thermal efficiency	%	90,8	94,4	95,3	94,3	91,8
Minimum thermal efficiency	%	89,6	94,1	94,4	94,1	92,8
Energy efficiency class	-	A+	A+	A+	A+	A+
Max. permissible work pressure	bar	1,5				
Required flue gas draught	mbar	0,16	0,17	0,17	0,21	0,24
Water temperature on supply max.	°C	65/80				
Boiler weight ³	kg	321	327	353	360	396
Boiler water tank capacity	l	54	60	70	75	81
Chimney section	cmxcm	14x14	14x14	14x14	16x16	18x18
Chimney section	Ø mm	160	160	160	180	200
Minimum chimney height	m	5,5	6,5	7	7	7
Supply and return socket diameter	mm	G1 ½"				
Diameter of the exhaust gas socket	mm	159	159	159	159	178
Supply	V/Hz	~230/50				

¹ Maximum area of heated rooms estimated for unit heat demand $q=90 \text{ W/m}^2$.

² Fuel tank capacity for pellet bulk density $0,6 \text{ kg/dm}^3$.

³ Boiler weight depends on its additional equipment.

Height of boiler can be additionally adjusted by means of provided levelling legs. The regulation of legs varies from 38 to 50 mm.

Additional equipment components shall be added during ordering of the boiler because there is no possibility of installation in the future.

SMART EKOPELL | 12-38 kW



EcoDesign requirements fulfilled for all powers.

The boiler meets the requirements of the class 5 acc. to the PN-EN 303-5:2012 for all powers.

Fuel: Wood pellet with diameter 6 mm.



5 years warranty for heat exchanger tightness, 2 years for the remaining components and efficient operation of boiler;



Heat exchanger made of certified high-grade steel;



91,7-94,6%

High thermal efficiency in the range from 91,7 to 94,6% due to increased heat recovery from flue gases;



APC 3 ADAPTIVE CONTROL 3 servicing six pumps /central heating, domestic hot water, circulating, floor/. Control of two mixing valves; preview and change of parameters of the main controller ONLINE through built-in internet module with RJ-45 connector;



Boiler adapted for installation in the closed system provided that protections were installed in accordance with the operation and maintenance manual of the boiler;



Pellet burner with automatic cleaning function in standard;



ADAPTIVE CONTROL control - adjustment of boiler operation based on air flow through the heat exchanger;



Ceramic catalysts stabilising combustion process;



Fuel self-ignition system;



Exhaust fan eliminating problem with chimney draught and stabilising operation of the boiler;



Fuel reserve sensor in container stops boiler operation at minimum fuel level. After fuel recharging it is not necessary to repeat firing procedure and the boiler switches to automatic operation;



APC 3 CONTROLLER



ADAPTIVE CONTROL

SMART EKOPELL

BOILER DIMENSIONS IN MM

Dimension	12 kW	16 kW	20 kW	24 kW	28 kW	38 kW
A1	156	156	156	156	156	156
A2	844	844	844	844	953	1063
A3	126	126	126	126	126	126
B	552	602	602	602	602	602
C	650	650	650	650	650	650
D	1370	1410	1410	1410	1410	1410
E	1012	1012	1012	1012	1121	1231
F	1135	1135	1135	1135	1244	1354
G	1015	1015	1015	1015	1182	1332
H	1361	1361	1361	1361	1361	1361
I	259	259	259	259	296	296
J	701	701	761	831	831	831
K	Ø 130	Ø 130	Ø 130	Ø 130	Ø 130	Ø 130
L	1318	1318	1376	1481	1581	1568
M	1210	1260	1260	1260	1260	1260

BOILER EQUIPMENT / PRODUCT TYPE C

Name	Additional equipment
APC 3 ADAPTIVE CONTROL controller	standard
ADAPTIVE CONTROL control system	standard
PID function	standard
INTERNET module	standard
levelling legs	standard
NZ version for closed system	standard
igniter	standard
exhaust fan	standard
pellet burner with automatic cleaning function	standard
GSM module	extra charge *
WIFI INTERNET module	extra charge *
room controller DEFRO SPK Lux	extra charge *
ST-292 v3 room controller	extra charge *
I-1 module	extra charge *
I-1m module	extra charge *
ST-292 v2 room controller	extra charge *
SPK Lux wireless regulator	extra charge *
set for wireless communication RS	extra charge *

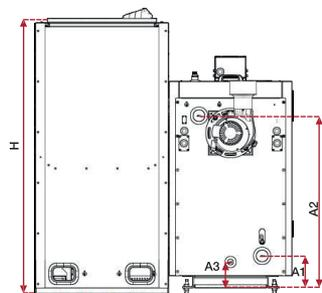
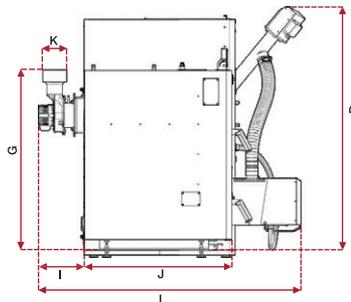
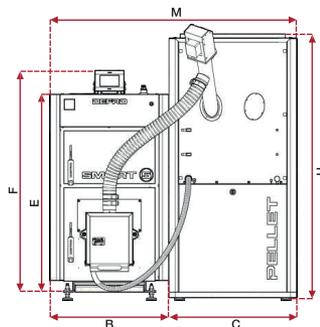

TECHNICAL DATA OF THE BOILER / PRODUCT GROUP A

Specification / boiler type	unit	12	16	20	24	28	38
Fuel	-	wood pellet with diameter 6 mm					
5 class according to PN-EN 303:5-2012	-	✓	✓	✓	✓	✓	✓
Ecodesign	-	✓	✓	✓	✓	✓	✓
Power range	kW	3,6-12	4,8-16	6,0-20	7,2-24	8,4-28	11,4-38
Heating area	m ²	1,6	1,8	2,2	2,6	3,2	3,6
Area of heated rooms ¹	m ²	to 150	to 200	to 250	to 300	to 350	to 475
Capacity of fuel container ²	kg	~195	~195	~195	~195	~195	~195
Nominal thermal efficiency	%	94,6	94,5	93,4	91,7	93,1	93,8
Minimum thermal efficiency	%	93,4	93,7	93,2	91,9	93,4	93,1
Energy efficiency class	-	A+	A+	A+	A+	A+	A+
Max. permissible work pressure	bar	1,5					
Required flue gas draught	mbar	0,20	0,22	0,24	0,26	0,28	0,29
Water temperature on supply max.	°C	65/80					
Boiler weight ³	kg	374	396	424	451	493	528
Boiler water tank capacity	l	51	57	64	73	86	98
Chimney section	cmxcm	14x14	14x14	14x14	15x15	16x16	18x18
Chimney section	Ø mm	160	160	160	170	180	200
Minimum chimney height	m	6	6,5	7	7,5	8	9
Supply and return socket diameter	mm	G1 ½"					
Diameter of the exhaust gas socket	mm	130	130	130	130	130	130
Supply	V/Hz	~230/50					

¹ Maximum area of heated rooms estimated for unit heat demand $q=80 \text{ W/m}^2$.

² Fuel tank capacity for pellet bulk density $0,6 \text{ kg/dm}^3$.

³ Boiler weight depends on its additional equipment.

Height of boiler can be additionally adjusted by means of provided levelling legs. The regulation of legs varies from 38 to 50 mm.

Additional equipment components shall be added during ordering of the boiler because there is no possibility of installation in the future.

KOMPAKT EKOPELL | 20-75 kW



EcoDesign requirements fulfilled for all powers.

The boiler meets the requirements of the class 5 acc. to the PN-EN 303-5:2012 for all powers.

Fuel: Wood pellet with diameter 6 mm.



5 years warranty for heat exchanger tightness, 2 years for the remaining components and efficient operation of boiler;



Heat exchanger made of certified high-grade steel;



90,1 - 93,9%

High thermal efficiency in the range from 90,1 to 93,9% due to increased heat recovery from flue gases;



APC 3 ADAPTIVE CONTROL 3 servicing six pumps /central heating, domestic hot water, circulating, floor/. Control of two mixing valves; preview and change of parameters of the main controller ONLINE through built-in internet module with RJ-45 connector;



Boiler adapted for installation in the closed system provided that protections were installed in accordance with the operation and maintenance manual of the boiler;



Pellet burner with automatic cleaning function in standard;



F Version -version with automatic cleaning and ash removal (extra payable according to the price list of boiler equipment)



ADAPTIVE CONTROL control - adjustment of boiler operation based on air flow through the heat exchanger;



Ceramic catalysts stabilising combustion process;



Fuel self-ignition system;



Exhaust fan eliminating problem with chimney draught and stabilising operation of the boiler;



Fuel reserve sensor in container stops boiler operation at minimum fuel level. After fuel recharging it is not necessary to repeat firing procedure and the boiler switches to automatic operation;



APC 3 CONTROLLER



ADAPTIVE CONTROL



KOMPAKT EKOPELL



KOMPAKT EKOPELL F

KOMPAKT EKOPELL

BOILER DIMENSIONS IN MM

Wymiar	20 kW	26 kW	35 kW	40 kW	56 kW	75 kW
A	600	600	650	700	750	750
B	600	600	650	700	750	600
C	1200	1200	1300	1400	1500	1500
D (wersja F)	1261	1261	1361	1461	1561	1561
E	1181	1181	1281	1501	1551	1586
F	1303	1303	1403	-	-	-
G	1205	1205	1363	1573	1552	1552
H	130	130	130	130	127	127
I	801	851	911	961	1001	1292
J	1384	1470	1569	1649	1711	1993
K	1030	1030	1131	1351	1401	1421
L	126	126	126	126	126	126

BOILER EQUIPMENT / PRODUCT TYPE C

Name	Additional equipment
APC 3 ADAPTIVE CONTROL controller	standard
ADAPTIVE CONTROL control system	standard
PID function	standard
INTERNET module	standard
levelling legs	standard
NZ version for closed system	standard
igniter	standard
exhaust fan	standard
system for mechanical cleaning of heat exchanger	standard
pellet burner with automatic cleaning function	standard
GSM module	extra charge *
WIFI INTERNET module	extra charge *
room controller DEFRO SPK Lux	extra charge *
ST-292 v3 room controller	extra charge *
ST-292 v2 room controller	extra charge *
I-1 module	extra charge *
I-1m module	extra charge *
SPK Lux wireless regulator	extra charge *
set for wireless communication RS	extra charge *
automatic cleaning and ash removal system	extra charge *

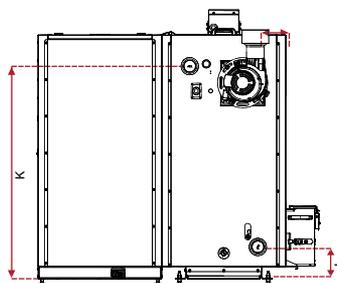
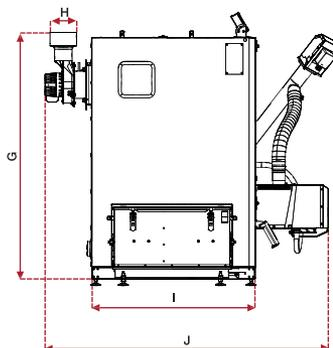
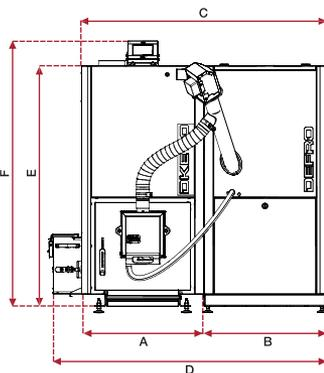

TECHNICAL DATA OF THE BOILER / PRODUCT GROUP A

Specification / boiler type	unit	20	26	35	40	56	75
Fuel	-	wood pellet with diameter 6 mm					
5 class according to PN-EN 303:5-2012	-	✓	✓	✓	✓	✓	✓
Ecodesign	-	✓	✓	✓	✓	✓	✓
Power range	kW	5,3-18,9	7,5-24,8	10,1-34,1	12,0-39,7	16,5-56,9	20,3-79,1
Capacity of fuel container ¹	kg	~143	~149	~199	~303	~353	~392
Nominal thermal efficiency	%	93,3	93,9	92,9	92,1	91,7	90,1
Minimum thermal efficiency	%	93,3	94,5	93,2	91,9	91,3	92,8
Energy efficiency class	-	A+	A+	A+	A+	A+	A+
Max. permissible work pressure	bar	3,0					
Required flue gas draught	mbar	0,18	0,22	0,28	0,28	0,29	0,35
Water temperature on supply max.	°C	65/80					
Boiler weight ² (wersja STD / F)	kg	407/442	429/466	483/511	598/628	716/808	980/1025
Boiler water tank capacity	l	97	100	130	176	193	273
Supply and return socket diameter	cal	G1 ½"					
Diameter of the exhaust gas socket	mm	130	130	130	130	127	127
Supply	V/Hz	~230/50					

¹ Fuel tank capacity for pellet bulk density 0,6 kg/dm³.

² Boiler weight depends on its additional equipment.

Height of boiler can be additionally adjusted by means of provided levelling legs. The regulation of legs varies from 38 to 50 mm.

Additional equipment components shall be added during ordering of the boiler because there is no possibility of installation in the future.

* According to the current price list.

EKO SLIM | 10-30 kW



EcoDesign requirements fulfilled for all powers.

The boiler meets the requirements of the class 5 acc. to the PN-EN 303-5:2012 for all powers.

Fuel: Wood pellet with diameter 6 mm.



5 years warranty for heat exchanger tightness, 2 years for the remaining components and efficient operation of boiler;

STEEL



Heat exchanger made of certified high-grade steel;



91,4 - 92,7%

High thermal efficiency in the range from 90,2 to 93,1% due to increased heat recovery from flue gases;

APC K SLIM

APC K SLIM ADAPTIVE CONTROL servicing four pumps /central heating, domestic hot water, floor/. Control of one mixing valve: preview and change of parameters of the main ONLINE controller - extra payable option;



Boiler adapted for installation in the closed system provided that protections were installed in accordance with the operation and maintenance manual of the boiler;

ADAPTIVE CONTROL

ADAPTIVE CONTROL control - adjustment of boiler operation based on air flow through the heat exchanger;



Ceramic catalysts stabilising combustion process;



Fuel self-ignition system;



Pellet burner with automatic cleaning function in standard;



Compact dimensions;



APC K SLIM CONTROLLER



ADAPTIVE CONTROL

EKO SLIM

BOILER DIMENSIONS IN MM

Dimension	10 kW	15 kW	20 kW	25 kW	30 kW
A	602	602	702	702	802
B	583	567	612	618	590
C	Ø 127	Ø 159	Ø 159	Ø 159	Ø 159
D	1615	1615	1650	1650	1650
E	705	915	915	855	855
F	356	356	356	392	392
G	1256	1481	1481	1422	1422

BOILER EQUIPMENT / PRODUCT TYPE C

Name	Additional equipment
APC K Slim controller	standard
ADAPTIVE CONTROL control system	standard
PID function	standard
levelling legs	standard
igniter	standard
pellet burner with automatic cleaning function	standard
GSM module	extra charge *
INTERNET module	extra charge *
WIFI INTERNET module	extra charge *
room controller DEFRO SPK Lux	extra charge *
ST-292 v3 room controller	extra charge *
ST-292 v2 room controller	extra charge *
I-1 module	extra charge *
I-1m module	extra charge *
SPK Lux wireless regulator	extra charge *
set for wireless communication RS	extra charge *
platform	extra charge *

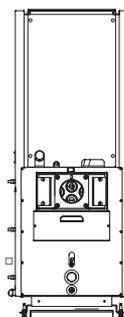
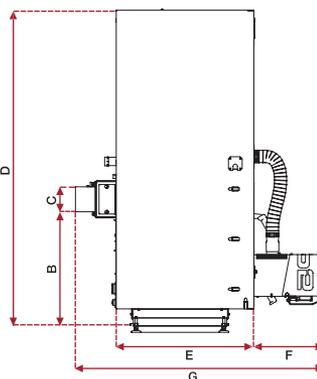
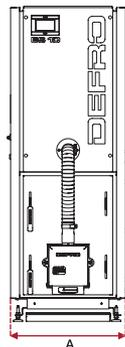

TECHNICAL DATA OF THE BOILER / PRODUCT GROUP D

Specification / boiler type	unit	10	15	20	25	30
Fuel	-	wood pellet with diameter 6 mm				
5 class according to PN-EN 303:5-2012	-	✓	✓	✓	✓	✓
Ecodesign	-	✓	✓	✓	✓	✓
Power range	kW	2,9-10,5	4,3-14,8	5,8-20,7	7,3-25,1	8,8-31,6
Heating area	m ²	1,5	2,1	2,5	2,7	3,3
Area of heated rooms ¹	m ²	to 160	to 220	to 270	to 355	to 425
Capacity of fuel container ²	kg	~102	~122	~126	~126	~147
Nominal thermal efficiency	%	91,8	91,8	91,4	91,7	91,8
Minimum thermal efficiency	%	91,5	92,3	92,7	92,1	92,5
Energy efficiency class	-	A+	A+	A+	A+	A+
Max. permissible work pressure	bar	1,5 opened system; 3,0 closed system				
Required flue gas draught	mbar	0,19	0,21	0,25	0,27	0,29
Water temperature on supply max.	°C	65/80				
Boiler weight ³	kg	288	336	380	368	402
Boiler water tank capacity	l	48	69	130	97	110
Chimney section	cmxcm	14x14	14x14	14x14	16x16	18x18
Chimney section	Ø mm	160	160	160	180	200
Minimum chimney height	m	5	6	7	7	7
Supply and return socket diameter	cal	GZ 1 1/4" / GW 1 1/4"				
Diameter of the exhaust gas socket	mm	127	159	159	159	159
Supply	V/Hz	~230/50				

¹ Maximum area of heated rooms estimated for unit heat demand $q=70 \text{ W/m}^2$.

² Fuel tank capacity for pellet bulk density $0,65 \text{ kg/dm}^3$.

³ Boiler weight depends on its additional equipment.

Height of boiler can be additionally adjusted by means of provided levelling legs. The regulation of legs varies from 38 to 50 mm.

Additional equipment components shall be added during ordering of the boiler because there is no possibility of installation in the future.

* According to the current price list.

BIO SLIM | 10-30 kW



EcoDesign requirements fulfilled for all powers.

The boiler meets the requirements of the class 5 acc. to the PN-EN 303-5:2012 for all powers.

Fuel: Wood pellet with diameter 6 mm.



5 years warranty for heat exchanger tightness, 2 years for the remaining components and efficient operation of boiler;



Heat exchanger made of certified high-grade steel;



High thermal efficiency in the range from 91,4 to 94,2% due to increased heat recovery from flue gases;



APC 3 ADAPTIVE CONTROL 3 servicing six pumps /central heating, domestic hot water, circulating, floor/. Control of two mixing valves; preview and change of parameters of the main controller ONLINE through built-in internet module with RJ-45 connector;



Boiler adapted for installation in the closed system provided that protections were installed in accordance with the operation and maintenance manual of the boiler;



Pellet burner with automatic cleaning function in standard;



ADAPTIVE CONTROL control - adjustment of boiler operation based on air flow through the heat exchanger;



Ceramic catalysts stabilising combustion process;



Fuel self-ignition system;



Exhaust fan eliminating problem with chimney draught and stabilising operation of the boiler;



Fuel reserve sensor in container stops boiler operation at minimum fuel level. After fuel recharging it is not necessary to repeat firing procedure and the boiler switches to automatic operation;



Compact dimensions;



APC 3 CONTROLLER



ADAPTIVE CONTROL

BIO SLIM

BOILER DIMENSIONS IN MM

Dimension	10 kW	15 kW	20 kW	25 kW	30 kW
A	602	602	702	702	802
B	190	190	190	190	190
C	Ø 130	Ø 130	Ø 130	Ø 130	Ø 130
D	1615	1615	1650	1650	1650
E	840	840	925	925	925
F	1366	1578	1548	1521	1558
G	705	915	915	855	855
H	356	356	356	392	392
I	902	902	947	953	982

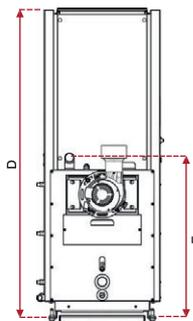
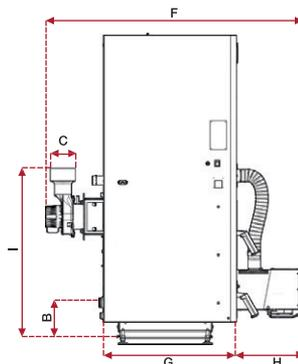
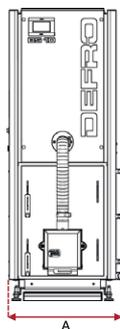

BOILER EQUIPMENT / PRODUCT TYPE C

Name	Additional equipment
APC 3 ADAPTIVE CONTROL controller	standard
ADAPTIVE CONTROL control system	standard
PID function	standard
INTERNET module	standard
levelling legs	standard
igniter	standard
exhaust fan	standard
pellet burner with automatic cleaning function	standard
GSM module	extra charge *
WIFI INTERNET module	extra charge *
room controller DEFRO SPK Lux	extra charge *
ST-292 v3 room controller	extra charge *
ST-292 v2 room controller	extra charge *
I-1 module	extra charge *
I-1m module	extra charge *
SPK Lux wireless regulator	extra charge *
set for wireless communication RS platform	extra charge *

* According to the current price list.

TECHNICAL DATA OF THE BOILER / PRODUCT GROUP D

Specification / boiler type	unit	10	15	20	25	30
Fuel	-	wood pellet with diameter 6 mm				
5 class according to PN-EN 303:5-2012	-	✓	✓	✓	✓	✓
Ecodesign	-	✓	✓	✓	✓	✓
Power range	kW	3,1-10,5	4,4-15,5	5,9-20,4	7,3-25,2	8,9-31,5
Heating area	m ²	1,5	2,1	2,5	2,7	3,3
Area of heated rooms ¹	m ²	to 160	to 220	to 270	to 355	to 425
Capacity of fuel container ²	kg	~102	~122	~126	~126	~147
Nominal thermal efficiency	%	93,6	93,6	92,5	92,1	92,9
Minimum thermal efficiency	%	92,3	93,0	93,0	92,5	92,9
Energy efficiency class	-	A+	A+	A+	A+	A+
Max. permissible work pressure	bar	1,5 opened system; 3,0 closed system				
Required flue gas draught	mbar	0,19	0,22	0,26	0,27	0,29
Water temperature on supply max.	°C	65/80				
Boiler weight ³	kg	288	336	380	368	402
Boiler water tank capacity	l	48	69	109	97	110
Chimney section	cmxcm	14x14	14x14	14x14	16x16	18x18
Chimney section	Ø mm	160	160	160	180	200
Minimum chimney height	m	5	6	7	7	7
Supply and return socket diameter	cal	GZ 1 ¼" GW 1 ¼"				
Diameter of the exhaust gas socket	mm	130	130	130	130	130
Supply	V/Hz	~230/50				

¹ Maximum area of heated rooms estimated for unit heat demand $q=70 \text{ W/m}^2$.

² Fuel tank capacity for pellet bulk density $0,65 \text{ kg/dm}^3$.

³ Boiler weight depends on its additional equipment.

Height of boiler can be additionally adjusted by means of provided levelling legs. The regulation of legs varies from 38 to 50 mm.

Additional equipment components shall be added during ordering of the boiler because there is no possibility of installation in the future.

ALFA II | 12-40 kW



EcoDesign requirements fulfilled for all powers.

The boiler meets the requirements of the class 5 acc. to the PN-EN 303-5:2012 for all powers.

Fuel: Wood pellet with diameter 6 mm.



5 years warranty for heat exchanger tightness, 2 years for the remaining components and efficient operation of boiler;

STEEL

Heat exchanger made of certified high-grade steel;



High thermal efficiency in the range from 91,2 to 93,2% due to increased heat recovery from flue gases;

APC CENTER

APC CENTER servicing six pumps /central heating, domestic hot water, circulating, floor/. Control of two mixing valves; preview and change of parameters of the main controller ONLINE through built-in internet module with RJ-45 connector;



Boiler adapted for installation in closed system if the protections are assembled in accordance with the operation and maintenance manual of the boiler;



Exhaust fan eliminating problem with chimney draught and stabilising operation of the boiler;



Vacuum sensor protecting against incorrect combustion process;

TSS

Twin Spark System - pellet burner as standard equipped with two igniters;



Fuel reserve sensor in container stops boiler operation at minimum fuel level. After fuel recharging it is not necessary to repeat firing procedure and the boiler switches to automatic operation;



Ceramic catalysts stabilising combustion process;



Fuel self-ignition system;



Central pellet burner with automatic cleaning function as a standard;



Compact dimensions;



Automatic heat exchanger cleaning and ash removal system;



Hydraulic set with circulating pump and thermostatic valve as boiler protection against low return temperature;



Lambda probe - Smart algorithm optimizing the combustion process and ensuring the highest efficiency of the boiler with minimum emission of flue gas for the full range of powers;



ALFA II PLUS



ALFA II



ALFA II

BOILER DIMENSIONS IN MM

Dimension	12 kW	17 kW	22 kW	26 kW	30 kW	40 kW
A	470	490	510	570	610	660
B (STD / PLUS)	1176/1496	1196/1516	1216/1536	1336/1656	1416/1696	1516/1746
C	1263	1263	1363	1363	1418	1418
D	1223	1281	1381	1381	1436	1364
E	130	130	130	130	130	127
F	775	775	775	815	815	835
G	1025	1068	1068	1107	1107	1127
H	1088	1088	1188	1188	1243	1243
I (STD / PLUS)	560 / 880	560 / 880	560 / 880	620 / 940	660 / 940	710 / 940

BOILER EQUIPMENT / PRODUCT TYPE C

Name	Additional equipment
APC CENTER controller	standard
PID function	standard
levelling legs	standard
igniter	standard
central pellet burner with automatic cleaning function	standard
hydraulic kit with thermostatic valve and circulation pump	standard
GSM module	extra charge *
INTERNET module	extra charge *
WIFI INTERNET module	extra charge *
room controller DEFRO SPK Lux	extra charge *
I-1 module	extra charge *
I-1m module	extra charge *
SPK Lux wireless regulator	extra charge *
ST-292 v3 room controller	extra charge *
ST-292 v2 room controller	extra charge *
set for wireless communication RS	extra charge *
extra charge for PLUS version - enlarged container	extra charge *

* According to the current price list.

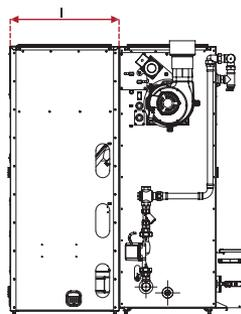
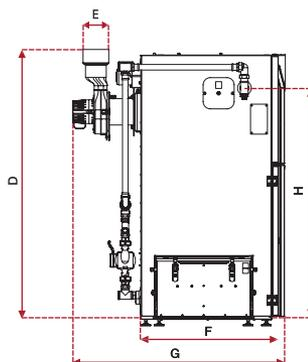
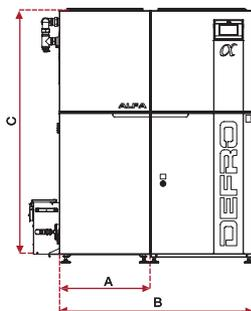

TECHNICAL DATA OF THE BOILER / PRODUCT GROUP D

Specification / boiler type	unit	12	17	22	26	30	40
Power range	kW	3,2-12,2	4,9-17,1	6,5-22,5	7,5-26,6	8,9-31,5	11,8-40,3
Heating area	m ²	1,4	1,6	1,9	2,3	2,7	3,0
5 class according to PN-EN 303:5-2012		✓	✓	✓	✓	✓	✓
Ecodesign		✓	✓	✓	✓	✓	✓
Area of heated rooms ¹	m ²	to 150	to 215	to 275	to 325	to 375	to 500
Capacity of fuel container (STD/PLUS) ²	kg	~85/ ~145	~85/ ~145	~110/ ~180	~120/ ~190	~145/ ~210	~165/ ~225
Nominal thermal efficiency	%	90,7	90,7	90,5	90,5	90,5	90,7
Minimum thermal efficiency	%	91,2	91,2	91,1	91,1	90,4	90,9
Energy efficiency class	-	A+	A+	A+	A+	A+	A+
Max. permissible work pressure	bar	3,0					
Required flue gas draught	mbar	0,13	0,15	0,18	0,20	0,22	0,25
Water temperature on supply max.	°C	65/80					
Boiler weight ³	kg	357	373	400	452	488	551
Boiler water tank capacity	l	55	56	65	78	88	100
Supply and return socket diameter	cal	GW 1"					
Release socket diameter	cal	GW ½"					
Diameter of the exhaust gas socket	mm	130	130	130	130	130	127

¹ Maximum area of heated rooms estimated for unit heat demand $q=80 \text{ W/m}^2$.

² Fuel tank capacity for pellet bulk density $0,65 \text{ kg/dm}^3$.

³ Boiler weight depends on its additional equipment.

Height of boiler can be additionally adjusted by means of provided levelling legs. The regulation of legs varies from 38 to 50 mm.

Additional equipment components shall be added during ordering of the boiler because there is no possibility of installation in the future.

EPSILON | 10-25 kW



EcoDesign requirements fulfilled for all powers.

The boiler meets the requirements of the class 5 acc. to the PN-EN 303-5:2012 for all powers.

Fuel: Wood pellet with diameter 6 mm.



5 years warranty for heat exchanger tightness, 2 years for the remaining components and efficient operation of boiler;



Heat exchanger made of certified high-grade steel;



High thermal efficiency in the range from 90,6 to 94,1% due to increased heat recovery from flue gases;



APC CENTER - servicing six pumps /central heating, domestic hot water, circulating, floor/. Control of two mixing valves; preview and change of parameters of the main controller ONLINE through built-in internet module with RJ-45 connector;



Boiler adapted for installation in closed system if the protections are assembled in accordance with the operation and maintenance manual of the boiler;



Mechanical heat exchanger cleaning system; F Version -version with automatic cleaning and ash removal (extra payable according to the price list of boiler equipment);



Vacuum sensor protecting against incorrect combustion process;



APC CENTER CONTROLLER



Ceramic catalysts stabilising combustion process;



Fuel self-ignition system;



Central pellet burner with automatic cleaning function as a standard;



Lambda probe - Smart algorithm optimizing the combustion process and ensuring the highest efficiency of the boiler with minimum emission of flue gas for the full range of powers;



Exhaust fan eliminating problem with chimney draught and stabilising operation of the boiler;



Compact dimensions;



Fuel reserve sensor in container stops boiler operation at minimum fuel level. After fuel recharging it is not necessary to repeat firing procedure and the boiler switches to automatic operation;



Twin Spark System - pellet burner as standard equipped with two igniters;



EPSILON



EPSILON F

EPSILON

BOILER DIMENSIONS IN MM EPSILON / EPSILON F

Dimension	10 kW	15 kW	20 kW	25 kW
A	540 / 726	540 / 726	615 / 801	745 / 931
B	1290	1290	1290	1290
C	66 / -	66 / -	66 / -	66 / -
D	1040	1040	1040	1040
E	1074	1074	1074	1074
F	100	100	100	100
G	167	167	167	167
H	154	154	154	154

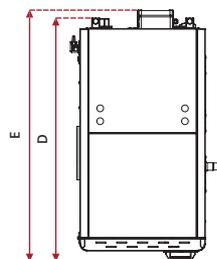
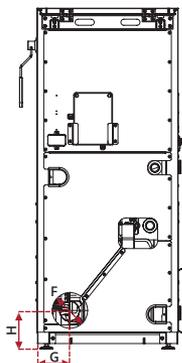
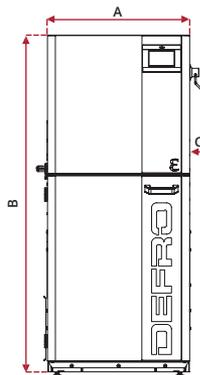

BOILER EQUIPMENT / PRODUCT TYPE C

Name	Additional equipment
APC CENTER controller	standard
PID function	standard
levelling legs	standard
igniter	standard
central pellet burner with automatic cleaning function	standard
GSM module	extra charge *
INTERNET module	extra charge *
WIFI INTERNET module	extra charge *
room controller DEFRO SPK Lux	extra charge *
I-1 module	extra charge *
I-1m module	extra charge *
SPK Lux wireless regulator	extra charge *
ST-292 v3 room controller	extra charge *
ST-292 v2 room controller	extra charge *
set for wireless communication RS	extra charge *
extra charge for PLUS version - enlarged container	extra charge *

* According to the current price list.

TECHNICAL DATA OF THE BOILER / PRODUCT GROUP D

Specification / boiler type	unit	10	15	20	25
Power range	kW	3,0-10,3	4,2-14,5	5,5-20,7	7,2-25,5
5 class according to PN-EN 303:5-2012	-	✓	✓	✓	✓
Ecodesign	-	✓	✓	✓	✓
Capacity of fuel container (STD / PLUS) ¹	kg	~58 / ~129	~58 / ~129	~67 / ~147	~82 / ~180
Nominal thermal efficiency	%	90,6	90,9	90,5	90,8
Minimum thermal efficiency	%	90,8	90,5	90,9	90,6
Energy efficiency class		A+	A+	A+	A+
Max. permissible work pressure	bar	3,0			
Required flue gas draught	mbar	0,13	0,13	0,17	0,20
Water temperature on supply max.	°C	65/80			
Boiler weight (STD / PLUS) ²	kg	~275 / ~285	~286 / ~296	~316 / ~328	~366 / ~379
Boiler water tank capacity	l	48	45	50	60
Supply	V/Hz	~230V/50Hz			
Supply and return socket diameter	cal	1"			
Release socket diameter	cal	½"			
Diameter of the exhaust gas socket	mm	100	100	100	100

¹ Fuel tank capacity for pellet bulk density 0,6 kg/dm³.

² Boiler weight depends on its additional equipment.

Height of boiler can be additionally adjusted by means of provided levelling legs. The regulation of legs varies from 38 to 50 mm.

GAMMA | 10-40 kW



EcoDesign requirements fulfilled for all powers.

The boiler meets the requirements of the class 5 acc. to the PN-EN 303-5:2012 for all powers.

Fuel: Wood pellet with diameter 6 mm.



5 years warranty for heat exchanger tightness, 2 years for the remaining components and efficient operation of boiler;



Heat exchanger made of certified high-grade steel;



91,7-94,2%

High thermal efficiency in the range from 91,7 to 94,2% due to increased heat recovery from flue gases;



APC K SLIM ADAPTIVE CONTROL servicing four pumps /central heating, domestic hot water, floor/. Control of one mixing valve; preview and change of parameters of the main ONLINE controller - extra payable option;



Boiler adapted for installation in the closed system provided that protections were installed in accordance with the operation and maintenance manual of the boiler;



Mechanical heat exchanger cleaning system;



ADAPTIVE CONTROL control - adjustment of boiler operation based on air flow through the heat exchanger;



Ceramic catalysts stabilising combustion process;



Fuel self-ignition system;



Pellet burner with automatic cleaning function in standard;



Possibility of moving the fuel tank;



Compact dimensions;



APC K SLIM CONTROLLER



ADAPTIVE CONTROL

GAMMA

BOILER DIMENSIONS IN MM

Dimension	10 kW	15 kW	20 kW	25 kW	30 kW	40 kW
A	557	557	607	657	757	757
B	605	605	605	605	805	805
C	1162	1162	1212	1260	1560	1560
D	1345	1495	1495	1495	1495	1495
E	1075	1225	1206	1206	1206	1206
F	159	159	178	178	178	178
G	617	617	617	617	617	777
H	100	100	100	100	100	100

BOILER EQUIPMENT / PRODUCT TYPE C

Name	Additional equipment
APC K Slim controller	standard
ADAPTIVE CONTROL	standard
PID function	standard
system for automatic cleaning of heat exchanger	standard
levelling legs	standard
igniter	standard
central pellet burner with automatic cleaning function	standard
GSM module	extra charge *
INTERNET module	extra charge *
WIFI INTERNET module	extra charge *
ST-292 v3 room controller	extra charge *
ST-292 v2 room controller	extra charge *
I-1 module	extra charge *
I-1m module	extra charge *
room controller DEFRO SPK Lux	extra charge *
SPK Lux wireless regulator	extra charge *
set for wireless communication RS	extra charge *

* According to the current price list.

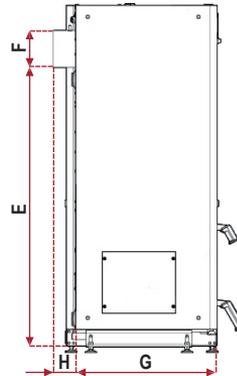
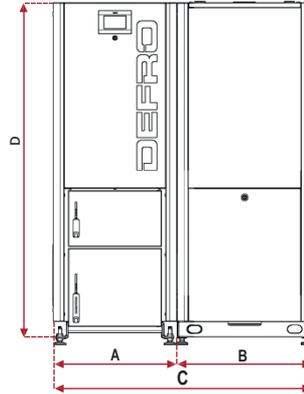

TECHNICAL DATA OF THE BOILER / PRODUCT GROUP D

Specification / boiler type	unit	10	15	20	25	30	40
Power range	kW	3,0-10	4,5-15	6,0-20	7,5-25	9,0-30	12,5-40
5 class according to PN-EN 303:5-2012	-	✓	✓	✓	✓	✓	✓
Ecodesign	-	✓	✓	✓	✓	✓	✓
Heating area	m ²	1,3	1,5	1,9	2,3	3,0	4,2
Area of heated rooms ¹	m ²	to 125	to 185	to 250	to 310	to 375	to 500
Capacity of fuel container ²	kg	~114	~146	~146	~146	~189	~228
Nominal thermal efficiency	%	94,2	92,3	92,2	91,7	91,7	92,0
Minimum thermal efficiency	%	93,9	92,5	91,9	91,4	90,8	91,2
Energy efficiency class		A+	A+	A+	A+	A+	A+
Max. permissible work pressure	bar	1,5					
Required flue gas draught	mbar	0,12	0,15	0,18	0,18	0,20	0,25
Water temperature on supply max.	°C	65/80					
Boiler weight ³	kg	~355	~375	~411	~448	~543	~645
Boiler water tank capacity	l	77	96	103	111	128	168
Chimney section	cmxcm	14x14	14x14	16x16	16x16	18x18	20x20
Chimney section	Ø mm	160	160	180	180	200	220
Minimum chimney height	m	5	5	5	6	6	7
Supply and return socket diameter	cal	1 ½ "					
Release socket diameter	cal	½ "					
Diameter of the exhaust gas socket	mm	159	159	178	178	178	178

¹ Maximum area of heated rooms estimated for unit heat demand $q=80 \text{ W/m}^2$.

² Fuel tank capacity for pellet bulk density $0,65 \text{ kg/dm}^3$.

³ Boiler weight depends on its additional equipment.

Height of boiler can be additionally adjusted by means of provided levelling legs. The regulation of legs varies from 38 to 50 mm.

KOMFORT EKO LUX | 12-40 kW



EcoDesign requirements fulfilled for all powers.

The boiler meets the requirements of the class 5 acc. to the PN-EN 303-5:2012 for all powers.

Fuel: eco-pea coal 5-25 mm.



5 years warranty for heat exchanger tightness, 2 years for the remaining components and efficient operation of boiler;



Heat exchanger made of certified high-grade steel;



High thermal efficiency in the range from 89,9 to 90,7% due to increased heat recovery from flue gases;



Controller K1P v4 with colour touch panel servicing four pumps /central heating, domestic hot water, circulation, floor pump/. Servicing of mixing valve. Possibility to control using GSM or INTERNET - extra paid option; adjustable position angle of the control panel;



Boiler adapted for installation in the closed system provided that protections were installed in accordance with the operation and maintenance manual of the boiler;



Pressure equalisation system in fuel container;



ADAPTIVE CONTROL control - adjustment of boiler operation based on air flow through the heat exchanger;



Vertical or horizontal configuration of the flue after the installation of the torsion bend (the torsional bend does not constitute the boiler's equipment);



Ceramic catalysts stabilising combustion process;



Combustion chamber with highly effective retort burner;



Changing the direction of door opening (does not apply to the inner door);



Sensor indicating opened cover of the fuel tank;



Feeder screw made of one element;



Energy-saving high-efficiency motoreducer with an autoreverse in the case of a fuel feeder lock;



K1PV4 CONTROLLER



ABM MOTOREDUCER



KOMFORT EKO LUX

BOILER DIMENSIONS IN MM

Dimension	12 kW	15 kW	20 kW	25 kW	30 kW	40 kW
A	482	482	532	532	582	632
B	530	530	630	630	630	630
C	1409	1474	1524	1569	1569	1579
D	1203	1268	1318	1349	1349	1359
E	Ø 159	Ø 159	Ø 159	Ø 178	Ø 178	Ø 178
F	535	605	645	715	735	835
G	804	874	924	984	1004	1104

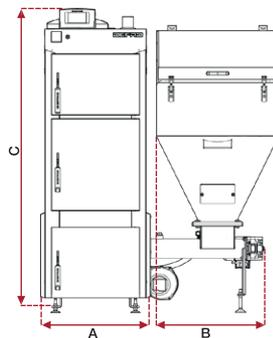

BOILER EQUIPMENT / PRODUCT TYPE C

Name	Additional equipment
controller K1Pv4	standard
ADAPTIVE CONTROL control system	standard
PID function	standard
levelling legs	standard
NZ version for closed system	standard
GSM module	extra charge *
INTERNET module	extra charge *
WIFI INTERNET module	extra charge *
room controller DEFRO SPK Lux	extra charge *
I-1 module	extra charge *
I-1m module	extra charge *
ST-292 v3 room controller	extra charge *
ST-292 v2 room controller	extra charge *
SPK Lux wireless regulator	extra charge *
set for wireless communication RS	extra charge *

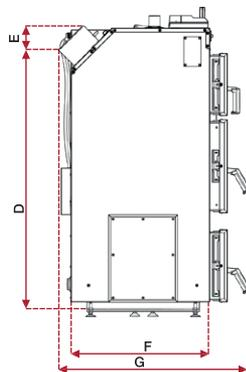

TECHNICAL DATA OF THE BOILER / PRODUCT GROUP A

Specification / boiler type	unit	12	15	20	25	30	40
Power range	kW	3,6-11,5	4,3-15,3	5,9-20,0	7,4-25,2	8,9-30,8	11,6-39,6
5 class according to PN-EN 303:5-2012	-	✓	✓	✓	✓	✓	✓
Ecodesign	--	✓	✓	✓	✓	✓	✓
Heating area	m ²	1,6	2,0	2,4	2,8	3,2	4,0
Area of heated rooms ¹	m ²	to 150	to 190	to 250	to 315	to 375	to 500
Capacity of fuel container ²	kg	~132	~132	~191	~191	~191	~258
Nominal thermal efficiency	%	89,6	89,9	90,1	90,4	89,7	90,2
Minimum thermal efficiency	%	90,0	89,3	89,8	89,5	89,8	89,4
Energy efficiency class		B	B	B	B	B	B
Max. permissible work pressure	bar	1,5					
Required flue gas draught	mbar	0,22	0,24	0,26	0,28	0,30	0,32
Water temperature on supply max.	°C	65/80					
Boiler weight ³	kg	407	456	529	568	626	769
Boiler water tank capacity	l	68	82	97	112	123	153
Chimney section	cmxcm	14x14	14x14	16x16	16x16	17x17	19x19
Chimney section	Ø mm	160	160	180	180	190	220
Minimum chimney height	m	5,5	6	6,5	7	7,5	8
Supply and return socket diameter	cal	1 ½ "					
Release socket diameter	cal	½ "					
Diameter of the exhaust gas socket	mm	159	159	159	178	178	178

¹ Maximum area of heated rooms estimated for unit heat demand $q=70 \text{ W/m}^2$.

² Fuel tank capacity for bulk density of eco-pea coal equal to $0,8 \text{ kg/dm}^3$.

³ Boiler weight depends on its additional equipment.

Height of boiler can be additionally adjusted by means of provided levelling legs. The regulation of legs varies from 38 to 50 mm.

ATTENTION! When ordering KOMFORT EKO LUX boiler the customer should specify on which side the container should be located (right or left).

Additional equipment components shall be added during ordering of the boiler because there is no possibility of installation in the future.

* According to the current price list.

KOMFORT EKO MINI | 11-40 kW



EcoDesign requirements fulfilled for all powers.

The boiler meets the requirements of the class 5 acc. to the PN-EN 303-5:2012 for all powers.

Fuel: eco-pea coal 5-25 mm.



5 years warranty for heat exchanger tightness, 2 years for the remaining components and efficient operation of boiler;



Heat exchanger made of certified high-grade steel;



89,4 - 91,1 %

High thermal efficiency in the range from 89,9 to 92,9% due to increased heat recovery from flue gases;



Controller K1P4 with colour touch panel servicing four pumps /central heating, domestic hot water, circulation, floor pump/. Servicing of mixing valve. Possibility to control using GSM or INTERNET - extra paid option; adjustable position angle of the control panel;



Boiler adapted for installation in the closed system provided that protections were installed in accordance with the operation and maintenance manual of the boiler;



Pressure equalisation system in fuel container;



Vertical or horizontal configuration of the flue after the installation of the torsion bend (the torsional bend does not constitute the boiler's equipment);



Ceramic catalysts stabilising combustion process;



Combustion chamber with highly effective retort burner;



Changing the direction of door opening (does not apply to the inner door);



Possibility of moving the fuel tank;



Feeder screw made of one element;



K1P4 CONTROLLER

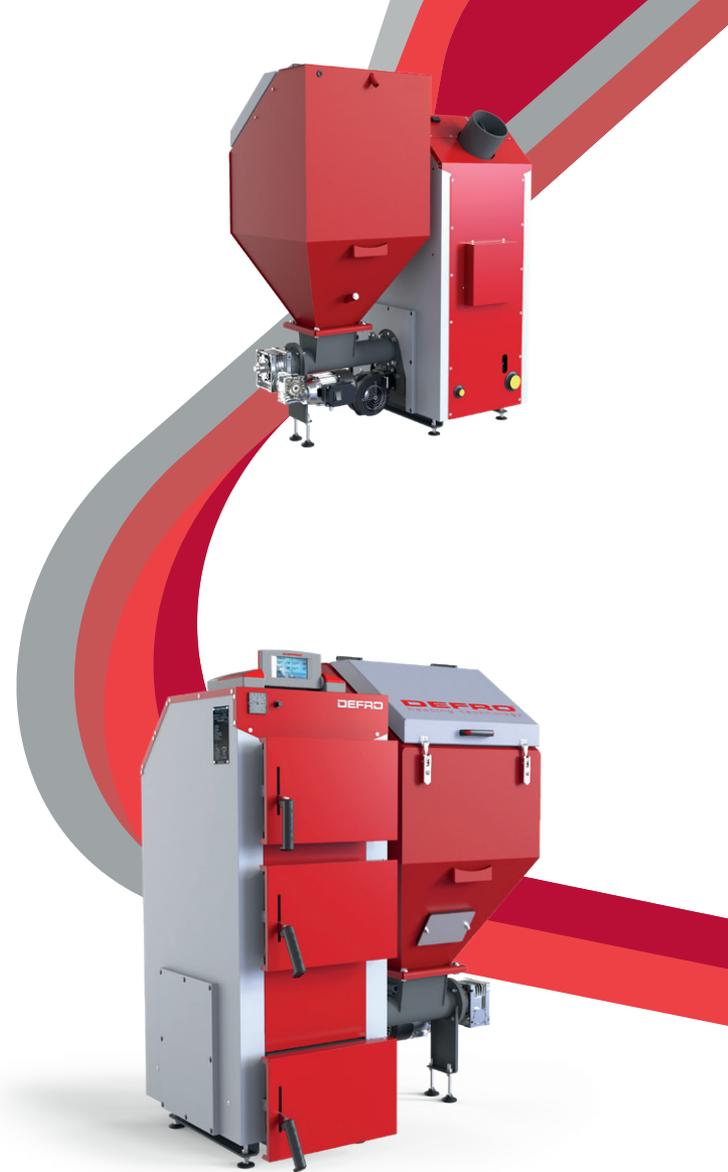

KOMFORT EKO MINI

BOILER DIMENSIONS IN MM

Dimension	11 kW	15 kW	20 kW	24 kW	40 kW
A	480	480	530	530	630
B	540	540	540	640	640
C	1358	1358	1358	1548	1578
D	1156	1156	1156	1332	1362
E	Ø 159	Ø 159	Ø 159	Ø 178	Ø 178
F	535	605	645	715	835
G	804	874	914	984	1104

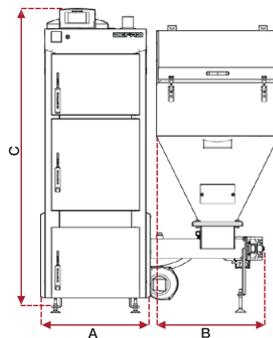

BOILER EQUIPMENT / PRODUCT TYPE C

Name	Additional equipment
K1P4 controller	standard
PID function	standard
ADAPTIVE CONTROL function	standard
leveling feet	standard
GSM module	extra charge *
I-1 module	extra charge *
I-1M module	extra charge *
Internet module	extra charge *
WiFi module	extra charge *
ST-292 v3 room controller	extra charge *
ST-292 v2 room controller	extra charge *
room controller DEFRO SPK Lux	extra charge *
SPK Lux wireless regulator	extra charge *
set for wireless communication RS	extra charge *

* According to the current price list.

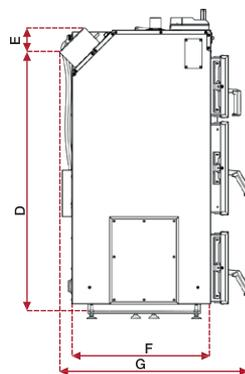

TECHNICAL DATA OF THE BOILER / PRODUCT GROUP D

Specification / boiler type	unit	11	15	20	24	40
Power range	kW	3,1-11,0	4,3-15,2	5,8-20,9	7,0-24,7	11,7-40,5
5 class according to PN-EN 303:5-2012	-	✓	✓	✓	✓	✓
Ecodesign	-	✓	✓	✓	✓	✓
Heating area	m ²	1,4	1,6	1,9	2,7	3,9
Area of heated rooms ¹	m ²	to 150	to 190	to 250	to 315	to 500
Capacity of fuel container ²	kg	~132	~132	~132	~191	~258
Nominal thermal efficiency	%	89,4	90,2	90,6	91,1	90,9
Minimum thermal efficiency	%	89,8	90,1	89,9	90,3	89,8
Energy efficiency class		B	B	B	B	B
Max. permissible work pressure	bar	1,5				
Required flue gas draught	mbar	0,21	0,25	0,16	0,30	0,34
Water temperature on supply max.	°C	65/80				
Boiler weight ³	kg	385	411	449	546	729
Boiler water tank capacity	l	60	68	78	104	144
Chimney section	cmxcm	14x14	14x14	14x14	16x16	22x22
Chimney section	Ø mm	160	160	160	180	245
Minimum chimney height	m	5,5	6	6	7	7
Supply and return socket diameter	cal	1 ½ "				
Release socket diameter	cal	½ "				
Diameter of the exhaust gas socket	mm	159	159	159	178	178

¹ Maximum area of heated rooms estimated for unit heat demand $q=80 \text{ W/m}^2$.

² Fuel tank capacity for bulk density of eco-pea coal equal to $0,8 \text{ kg/dm}^3$.

³ Boiler weight depends on its additional equipment.

Height of boiler can be additionally adjusted by means of provided levelling legs. The regulation of legs varies from 38 to 50 mm.

SIGMA E | 36-69 kW



Ecodesign requirements fulfilled for all powers.

The boiler meets the requirements of the class 5 acc. to the PN-EN 303-5:2012 for all powers.

Fuel: eco-pea coal 5-25 mm.



5 years warranty for heat exchanger tightness, 2 years for the remaining components and efficient operation of boiler;



Heat exchanger made of certified high-grade steel;



High thermal efficiency in the range from 90,0 to 90,7% due to increased heat recovery from flue gases;



Controller K1P v4 with colour touch panel servicing four pumps /central heating, domestic hot water, circulation, floor pump/. Servicing of mixing valve. Possibility to control using GSM or INTERNET - extra paid option; adjustable position angle of the control panel;



NZ version - adapted for installation in closed system, reinforced design, built-in cooling coil - extra paid option. NZ version available in power range 36-48 kW;



Combustion chamber with highly effective new-generation retort burner (solution submitted to the Patent Office of the Republic of Poland);



Ceramic catalysts stabilising combustion process;



Sensor indicating opened cover of the fuel tank;



Feeder screw made of one element;



Changing the direction of door opening (does not apply to the inner door);



ADAPTIVE CONTROL control - adjustment of boiler operation based on air flow through the heat exchanger;



Energy-saving high-efficiency motoreducer with an autoreverse in the case of a fuel feeder lock;



Mechanical heat exchanger cleaning system;



Pressure equalisation system in fuel container;



SIGMA E NZ



K1Pv4 CONTROLLER



ABM MOTOREDUCER

SIGMA E

BOILER DIMENSIONS IN MM

Dimension	36 kW	48 kW	69 kW
A	130	130	280
B	1115	1330	1170
C	Ø 178	Ø 194	Ø 245
D	1490	1710	1540
E	1595	1815	1645
F	1485	1685	1640
G	965	965	1130
H	115	115	115
I	1210	1210	1375
J	705	705	785
K	640	640	640
L	1460	1460	1465

BOILER EQUIPMENT / PRODUCT TYPE C

Name	Additional equipment
controller K1Pv4	standard
ADAPTIVE CONTROL control system	standard
PID function	standard
levelling legs	standard
system for mechanical cleaning of heat exchanger	standard
GSM module	extra charge *
INTERNET module	extra charge *
WIFI INTERNET module	extra charge *
"Fire Fighter" fire suppression system	extra charge *
NZ version for closed system	extra charge *
room controller DEFRO SPK Lux	extra charge *
ST-292 v3 room controller	extra charge *
ST-292 v2 room controller	extra charge *
I-1 module	extra charge *
I-1m module	extra charge *
SPK Lux wireless regulator	extra charge *
set for wireless communication RS	extra charge *

* According to the current price list.

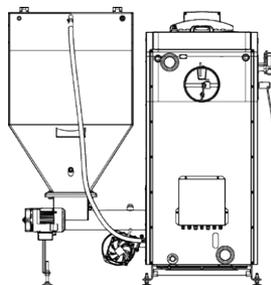
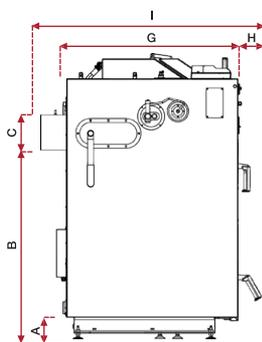
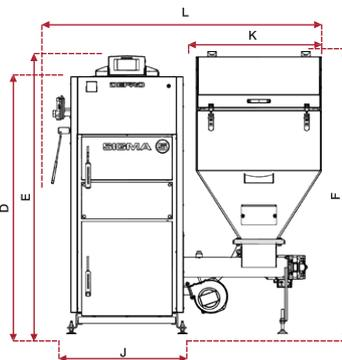

TECHNICAL DATA OF THE BOILER / PRODUCT GROUP A

Specification / boiler type	unit	36	48	69
Fuel		eco-pea coal 5-25 mm		
5 class according to PN-EN 303:5-2012	-	✓	✓	✓
Ecodesign	-	✓	✓	✓
Power range	kW	10,8-36	14,4-48	17,9-69
Heating area	m ²	4,3	5,2	6,5
Area of heated rooms ¹	m ²	to 450	to 600	to 825
Capacity of fuel container ²	kg	~191	~266	~258
Nominal thermal efficiency	%	90,1	90,9	90,0
Minimum thermal efficiency	%	90,8	90,4	90,5
Energy efficiency class	-	B	B	B
Max. permissible work pressure	bar	1,5 - opened system, 2,5 - closed system		
Required flue gas draught	mbar	0,31	0,34	0,34
Water temperature on supply max.	°C			
Boiler weight ³	kg	657	728	880
Boiler water tank capacity	l	170	200	230
Chimney section	cmxcm	18x18	22x22	24x24
Chimney section	Ø mm	200	250	270
Minimum chimney height	m	9	10	10
Supply and return socket diameter	mm	G1 ½"		
Diameter of the exhaust gas socket	mm	178	194	245
Supply	V/Hz	~230/50		

¹ Maximum area of heated rooms estimated for unit heat demand $q=80 \text{ W/m}^2$.

² Fuel tank capacity for bulk density of eco-pea coal equal to $0,8 \text{ kg/dm}^3$.

³ Boiler weight depends on its additional equipment.

Height of boiler can be additionally adjusted by means of provided levelling legs. The regulation of legs varies from 38 to 50 mm.

ATTENTION! When ordering the SIGMA E boiler the customer should specify on which side the container should be located (right or left).

Additional equipment components shall be added during ordering of the boiler because there is no possibility of installation in the future.

HYDROPELL | 8-24 kW

LOCAL ROOM HEATER FIRED WITH SOLID FUEL



EcoDesign requirements fulfilled for all powers.

Fuel: Wood pellet with diameter 6 mm.

HYDROPELL dry stove is intended for use as a room heater and may be used as a source of hot water for the central heating system. Part of hot air is emitted directly from the furnace through the window panel and by radiation through convection holes over the doors and in the top wall of the device. More than 80% of heat energy is given back to water in the water system of the stove.

Closed combustion chamber allows the installation of the HYDROPELL stove in rooms equipped with heat recovery.



Energy efficiency class A++;



5 years warranty for heat exchanger tightness;



Heat exchanger made of certified high-grade steel;



94,2-95,6%

High thermal efficiency in the range from 94,2 to 95,6% due to increased heat recovery from flue gases;



TIEMME controller. Operation of the central heating pump, automatic ignition process. Operation of the switching valve for the purposes of domestic hot water heating, domestic hot water heating mode. Cooperates with room controller or internal temp. sensor;



Equipment adapted for installation in the closed system if the protections are assembled in accordance with the operation and maintenance manual of the equipment;



Built-in expansion vessel;



Swirlers system increasing heat recovery from generated power;



The central heating pump being part of the equipment;



Fuel self-ignition system;



The furnace chamber is equipped with discharge pellet burner adapted for combustion of biomass;



Exhaust fan eliminating the problem with the chimney draught and stabilising the operation of the equipment;



Compact design;



HYDROPELL

BOILER DIMENSIONS IN MM

Dimension	8 kW	12 kW	18 kW	24 kW
A	525	525	575	575
B	887	937	987	1073
C	686	686	710	737
D	198	198	250	250
E	270	270	280	280
F	857	907	957	1043
G	400	400	450	450
H	110	110	116	116
I	119	119	119	119
J	50	50	50	50
K	80	80	80	80
L	136	189	181	181
M	186	206	197	197
N	169	127	134	134
O	93	136	153	153
P	120	79	126	126
R	128	70	138	138
S	60	60	50	60
T	50	50	50	50
U	528	623	623	623

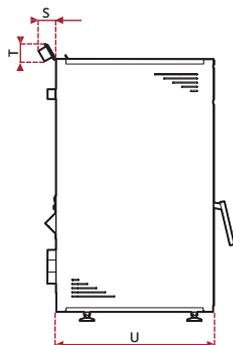
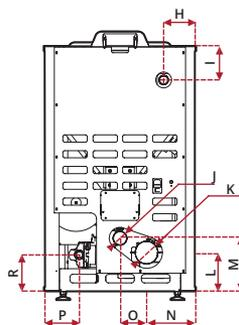
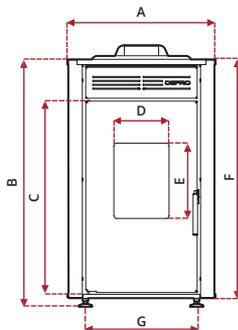

TECHNICAL DATA OF THE BOILER / PRODUCT GROUP D

Specification / type	unit	8	12	18	24
Nominal power	kW	10,4	12,4	14,9	18,5
Thermal power of water cycle	kW	8,5	10,3	12,3	16
Thermal power given off to the environment	kW	1,9	2,1	2,6	2,5
Nominal thermal efficiency	%	94,9	94,9	94,2	95,6
Minimum thermal efficiency	%	96,2	96,3	95,4	94,8
Seasonal energy efficiency	%	90,4	90,4	90,0	91,2
CO emissions at 13% O ₂	%	0,0101	0,0047	0,0048	0,0043
Flue gas temperature	°C	81,4	84,8	94,1	83,7
Weight ¹	kg	135	150	185	215
Minimal required flue gas draught	Pa	12	12	12	12
Diameter of the exhaust gas socket	mm	80	80	80	80
Supply	V	230	230	230	230
Maximum electric power consumption	W	380	380	380	380
Capacity of fuel container ²	kg	15	20	24	28
Water tank capacity	l	22	25	28	32
Expansion vessel capacity	l	5	5	8	8
Work pressure	bar	1,5	1,5	1,5	1,5

BOILER EQUIPMENT / PRODUCT TYPE C

Name	Additional equipment
TIEMME contrler	standard
exhaust fan	standard
pump	standard
Domestic hot water sensor	standard
Domestic hot water module	standard
built-in expansion vessel	standard
ZRS 3-way valve (PRODUCT TYPE F)	extra charge *
chimney reduction 80/100	extra charge *
Relay module for 3-wire switching valve	extra charge *
DHW sensor (purchased separately)	extra charge *

* According to the current price list.

¹ Device weight depends on its additional equipment

² Fuel tank capacity for pellet bulk density 600kg/m³

Height of device can be additionally adjusted by means of provided levelling legs. The regulation of legs varies from 38 to 50 mm.

BETA | 12-40 kW



EcoDesign requirements fulfilled for all powers.

The boiler meets the requirements of the class 5 acc. to the PN-EN 303-5:2012 for all powers.

Fuel: Wood pellet with diameter 6 mm.



5 years warranty for heat exchanger tightness, 2 years for the remaining components and efficient operation of boiler;



Heat exchanger made of certified high-grade steel;



91,7-95,3%

High thermal efficiency in the range from 91,7 to 95,3% due to increased heat recovery from flue gases;



APC CENTER servicing six pumps /central heating, domestic hot water, circulating, floor/. Control of two mixing valves; preview and change of parameters of the main controller ONLINE through built-in internet module with RJ-45 connector;



Boiler adapted for installation in the closed system provided that protections were installed in accordance with the operation and maintenance manual of the boiler;



Mechanical heat exchanger cleaning system;



Vacuum sensor protecting against incorrect combustion process;



APC CENTER CONTROLLER



Ceramic catalysts stabilising combustion process;



Fuel self-ignition system;



Central pellet burner with automatic cleaning function as a standard;



Lambda probe - Smart algorithm optimizing the combustion process and ensuring the highest efficiency of the boiler with minimum emission of flue gas for the full range of powers;



Exhaust fan eliminating problem with chimney draught and stabilising operation of the boiler;



Compact dimensions;



Fuel reserve sensor in container stops boiler operation at minimum fuel level. After fuel recharging it is not necessary to repeat firing procedure and the boiler switches to automatic operation;



Twin Spark System - pellet burner as standard equipped with two igniters;



BETA PLUS



BETA

BETA

BOILER DIMENSIONS IN MM

Dimension	12 kW	17 kW	22 kW	26 kW	30 kW	40 kW
A	470	490	490	530	610	670
B	958/1345	978/1365	978/1365	1127/1515	1207/1595	1327/1655
C	1336	1336	1491	1491	1491	1491
D	1304	1362	1517	1517	1517	1446
E	130	130	130	130	130	127
F	778	778	778	818	818	838
G	964	1001	1001	1041	1041	1025
H	635	635	635	675	675	695
I	487/874	487/874	487/874	596/984	596/984	656/984
J	163	160	160	180	220	207

BOILER EQUIPMENT / PRODUCT TYPE C

Name	Additional equipment
APC CENTER controller	standard
PID function	standard
system for mechanical cleaning of heat exchanger	standard
levelling legs	standard
igniter	standard
central pellet burner with automatic cleaning function	standard
GSM module	extra charge *
INTERNET module	extra charge *
WIFI INTERNET module	extra charge *
ST-292 v3 room controller	extra charge *
ST-292 v2 room controller	extra charge *
I-1 module	extra charge *
I-1m module	extra charge *
room controller DEFRO SPK Lux	extra charge *
SPK Lux wireless regulator	extra charge *
set for wireless communication RS	extra charge *

* According to the current price list.

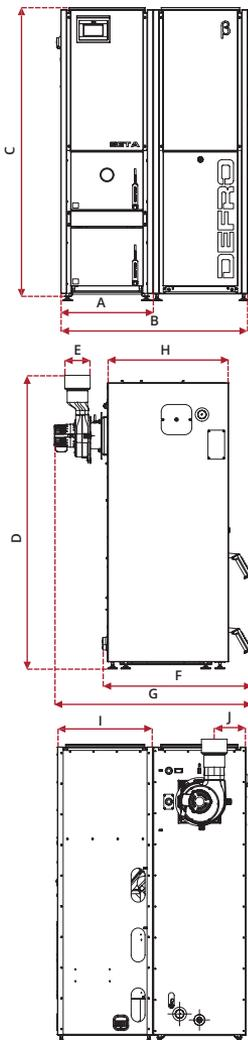

TECHNICAL DATA OF THE BOILER / PRODUCT GROUP A

Specification / boiler type	unit	12	17	22	26	30	40
Power range	kW	3,5-11,8	5,0-16,8	6,5-21,4	7,6-25,8	8,7-30,7	10,4-38,1
5 class according to PN-EN 303:5-2012	-	✓	✓	✓	✓	✓	✓
Ecodesign	-	✓	✓	✓	✓	✓	✓
Heating area	m ²	1,6	1,8	2,1	2,5	2,9	3,3
Area of heated rooms ¹	m ²	do 150	do 215	do 275	do 325	do 375	do 500
Capacity of fuel container (STD / PLUS) ²	kg	~77 / ~160	~77 / ~160	~104 / ~208	~135 / ~237	~135 / ~237	~153 / ~244
Nominal thermal efficiency	%	91,7	95,3	93,9	93,0	94,3	93,8
Minimum thermal efficiency	%	88,6	94,2	90,2	92,1	93,4	91,8
Energy efficiency class		A+	A+	A+	A+	A+	A+
Max. permissible work pressure	bar	3,0					
Required flue gas draught	mbar	0,12	0,16	0,20	0,21	0,24	0,25
Water temperature on supply max.	°C	65/80					
Boiler weight (STD / PLUS) ³	kg	~301 / ~321	~317 / ~337	~344 / ~366	~389 / ~410	~433 / ~454	~486 / ~503
Boiler water tank capacity	l	53	54	64	71	85	92
Chimney section	cmxcm	14x14	14x14	16x16	16x16	18x18	18x18
Chimney section	Ø mm	160	160	180	180	200	200
Minimum chimney height	m	5	5,5	6	6,5	7	7,5
Supply and return socket diameter	cal	1"					
Release socket diameter	cal	½"					
Diameter of the exhaust gas socket	mm	130	130	130	130	130	127

¹ Maximum area of heated rooms estimated for unit heat demand q=80 W/m².

² Fuel tank capacity for pellet bulk density 0,6 kg/dm³.

³ Boiler weight depends on its additional equipment.

Height of boiler can be additionally adjusted by means of provided levelling legs. The regulation of legs varies from 38 to 50 mm.

DWS | 12-22 kW



Ecodesign requirements fulfilled for all powers.

The boiler meets the requirements of the class 5 acc. to the PN-EN 303-5:2012 for all powers.

Fuel: eco-pea coal 20-25 mm.



3 years warranty for heat exchanger tightness, 2 years for the remaining components and efficient operation of boiler - if installed in accordance with the operation and maintenance manual of the boiler



Heat exchanger made of certified high-grade steel;



High thermal efficiency in the range from 89,8 to 91,4% due to increased heat recovery from flue gases;



Mechanical adjustment of combustion process using a knob in ash-pan doors and draught regulator;



Smoke chamber smoke removal system,



Boiler is prepared for mounting a set consisting of an exhaust fan and a controller. as a standard. The option is extra paid according to the price list of additional equipment.



Boiler is factory equipped with thermostatic draught regulator;



Nozzle reducing flue gas emission (The Patent Office of Republic of Poland protection);



Adjustment of secondary air inflow;



Boiler adapted for installation in the closed system provided that protections were installed in accordance with the operation and maintenance manual of the boiler;



Large charging chamber;



**AIR FAN KIT
(EXTRA CHARGE)**



DWS

BOILER DIMENSIONS IN MM

Dimension	12 kW	17 kW	22 kW
A	470	520	570
B	655	705	755
C	1315	1315	1395
D	1335	1335	1415
E	1041	1041	1101
F	159	159	178
G	656	656	656
H	1010	1010	1010

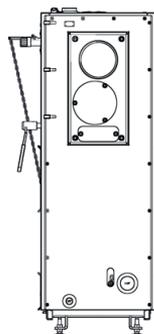
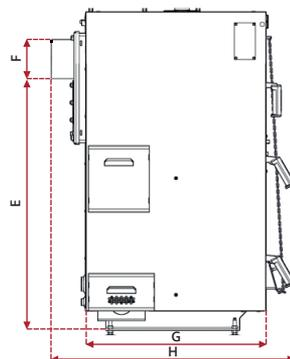
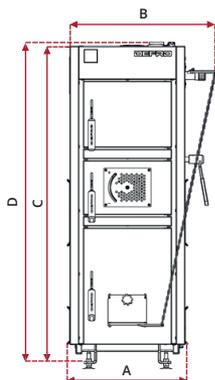

BOILER EQUIPMENT / PRODUCT TYPE C

Name	Additional equipment
draught regulator	standard
NZ version for closed system	standard
levelling legs	extra charge *
set consisting of an exhaust fan and ST-880 controller	extra charge *

* According to the current price list.

TECHNICAL DATA OF THE BOILER / PRODUCT GROUP A

Specification / boiler type	unit	12	17	22
Min. safe capacity of the storage container ¹	l	600	900	1200
5 class according to PN-EN 303:5-2012	-	✓	✓	✓
Ecodesign	-	✓	✓	✓
Heating area	m ²	2,4	2,7	3,1
Area of heated rooms ²	m ²	to 150	to 210	to 275
Single fuel charging ³	kg	~19	~23	~31
Optimum thermal efficiency	%	90,1	89,8	91,4
Energy efficiency class		B	B	B
Max. permissible work pressure	bar	1,5		
Required flue gas draught	mbar	0,19	0,21	0,23
Water temperature on supply max.	°C	65/90		
Boiler weight ⁴	kg	~379	~411	~465
Boiler water tank capacity	l	80	87	98
Chimney section	cmxcm	14x14	14x14	16x16
Chimney section	Ø mm	160	160	180
Minimum chimney height	m	5	5,5	6
Supply and return socket diameter	cal	1 ½"		
Release socket diameter	cal	½"		
Diameter of the exhaust gas socket	mm	159	159	178

¹ The minimum safe capacity of the accumulation tank calculated in accordance with PN-EN 303-5: 2012 for a 5 hour TB fuel burning time.

² Maximum area of heated rooms estimated for unit heat demand q=80 W/m².

³ For fuel bulk density 0,8 kg/dm³.

⁴ Boiler weight depends on its additional equipment.

Height of boiler can be additionally adjusted by means of provided levelling legs. The regulation of legs varies from 38 to 50 mm.

CALORI | 11-30 kW



EcoDesign requirements fulfilled for all powers.

The boiler meets the requirements of the class 5 acc. to the PN-EN 303-5:2012 for all powers.

Fuel: Wood pellet with diameter 6 mm.

WARRANTY
5
YEARS

5 years warranty for heat exchanger tightness, 2 years for the remaining components and efficient operation of boiler;

STEEL



Heat exchanger made of certified high-grade steel;



92,9-94,3%

High thermal efficiency in the range from 92,9 to 94,3% due to increased heat recovery from flue gases;

APC K SLIM

APC K SLIM ADAPTIVE CONTROL servicing three pumps /central heating, domestic hot water, floor/. Control of one mixing valve: preview and change of parameters of the main ONLINE controller - extra payable option;



Boiler adapted for installation in the closed system provided that protections were installed in accordance with the operation and maintenance manual of the boiler;

ADAPTIVE CONTROL



ADAPTIVE CONTROL control - adjustment of boiler operation based on air flow through the heat exchanger;



auto

Fuel self-ignition system;



Pellet burner with automatic cleaning function in standard;



Compact dimensions;



APC K SLIM CONTROLLER

CALORI

BOILER DIMENSIONS IN MM

Dimension	11 kW	15 kW	20 kW	24 kW	30 kW
A	630	630	755	755	780
B	359	359	374	374	414
C	159	159	159	159	159
D	1341	1341	1341	1341	1416
E	700	800	800	880	880
F	121	121	121	121	121
G	1182	1282	1257	1357	1372
H1	119	119	119	119	119
H2	380	380	395	395	435

BOILER EQUIPMENT / PRODUCT TYPE C

Name	Additional equipment
APC K Slim controller	standard
ADAPTIVE CONTROL control system	standard
PID function	standard
levelling legs	standard
igniter	standard
pellet burner with automatic cleaning function	standard
GSM module	extra charge *
INTERNET module	extra charge *
WIFI INTERNET module	extra charge *
room controller DEFRO SPK Lux	extra charge *
ST-292 v3 room controller	extra charge *
ST-292 v2 room controller	extra charge *
I-1 module	extra charge *
I-1m module	extra charge *
SPK Lux wireless regulator	extra charge *
set for wireless communication RS	extra charge *
platform	extra charge *

* According to the current price list.

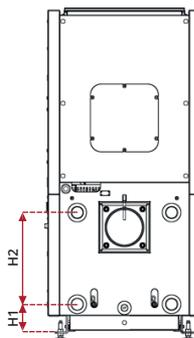
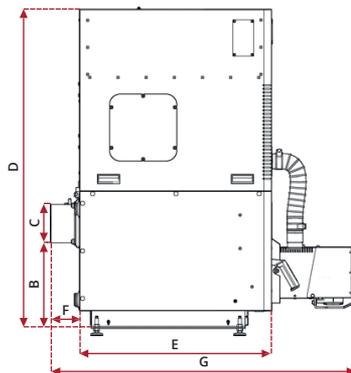
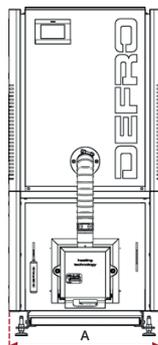

TECHNICAL DATA OF THE BOILER / PRODUCT GROUP D

Specification / boiler type	unit	11	15	20	24	30
Fuel	-	wood pellet with diameter 6 mm				
5 class according to PN-EN 303:5-2012	-	✓	✓	✓	✓	✓
Ecodesign	-	✓	✓	✓	✓	✓
Power range	kW	3,3-11,6	4,3-14,6	5,7-20,5	6,9-24,9	8,4-29,5
Heating area	m ²	1,4	1,8	2,3	2,6	2,9
Area of heated rooms ¹	m ²	to 135	to 185	to 250	to 310	to 375
Capacity of fuel container ²	kg	~90	~104	~118	~124	~142
Nominal power efficiency	%	92,9	93,2	93,2	94,3	93,3
Minimal power efficiency	%	92,1	92,2	92,4	93,1	92,9
Energy efficiency class	-	A+	A+	A+	A+	A+
Max. permissible work pressure	bar	3,0				
Required flue gas draught	mbar	0,14	0,17	0,20	0,23	0,26
Water temperature on supply max.	°C	65/80				
Boiler weight ³	kg	237	261	307	331	364
Boiler water tank capacity	l	50	60	75	86	95
Chimney section	cmxcm	14x14	14x14	14x14	16x16	18x18
Chimney section	Ø mm	160	160	160	180	200
Minimum chimney height	m	5	5	6	6	6
Supply and return socket diameter	cal	GZ 1 ¼" / GW 1 ¼"				
Diameter of the exhaust gas socket	mm	159	159	159	159	159
Supply	V/Hz	~230/50				

¹ Maximum area of heated rooms estimated for unit heat demand $q=80 \text{ W/m}^2$.

² Fuel tank capacity for pellet bulk density $0,6 \text{ kg/dm}^3$.

³ Boiler weight depends on its additional equipment.

Height of boiler can be additionally adjusted by means of provided levelling legs. The regulation of legs varies from 38 to 50 mm.

Additional equipment components shall be added during ordering of the boiler because there is no possibility of installation in the future.

DEFRO CONTROLLERS



APC CENTER

CONTROLLER FUNCTIONS:

- Control of up to two igniters;
- Fuel feeder control;
- Exhaust fan control;
- Central heating pump control - C.O. ;
- Controlling the domestic hot water pump - DHW;
- Smooth control of mixing valves;
- Control of additional pumps (up to two) with the possibility of choosing the type of device (central heating pump, domestic hot water pump, cyclical, breaker, short circulation pump);
- Independent control of ash removal and cleaning of the heat exchanger - not present in BETA boilers;
- Buffer support;
- Preview of the amount of fuel in the container, based on user calibration;
- Minimum fuel level sensor;
- Software update via USB;
- Built-in module controlling two mixing valves;
- Weather control of the valve;
- weekly control;
- Cooperation with two room controllers with traditional (two-state) communication, eg ST-292v3 and with a controller equipped with RS communication, eg SPK Lux - works only with controllers from the DEFRO distribution. Room regulators are a separate purchase;
- Possibility to connect the ST-65 GSM module - enables control of some functions of the controller using a mobile phone (only from DEFRO distribution) - an option for an additional charge;
- Built-in Ethernet module - allows you to control functions, view parameters via the Internet;
- Possibility to connect two additional valve control modules (only and exclusively from DEFRO distribution) - an option for an extra charge;
- The operation of the controller can be based on a reading from the Lambda probe (purchase additionally payable), which sends information about the oxygen content in the exhaust gas to the controller. On this basis, the quality of the combustion process is assessed and the operating parameters of the fan and fuel feeder are corrected;
- CH, DHW, valve, return, additional, exhaust gas and outside temperature sensor;
- feeder temperature sensor;
- Has thermal boiler temperature protection - STB sensor;
- Photoresistor (flame sensor controlling the quality of the flame);
- Has a vacuum sensor - controlling the combustion process;



K1PV4

CONTROLLER FUNCTIONS:

- Innovative ADAPTIVE CONTROL control using a turbine flow meter ensuring optimal selection of fan and feeder operation parameters;
- Operation based on the PID control algorithm - calculation of the blow-in power based on the measurement of the boiler temperature and flue gas measured at the boiler outlet;
- Ability to export temperature history to an external USB memory;
- Possibility of cooperation with the exhaust fan module;
- Fan and screw feeder control;
- Mixing valve servo control as standard;
- weekly control;
- CH and DHW pump control;
- Control of two additional pumps;
- Preview of the amount of fuel in the container, based on user calibration;
- Cooperation with a room regulator with traditional (two-state) communication, eg ST-292v3 or equipped with RS communication, eg SPK Lux - works only with controllers from the DEFRO distribution. Room regulators are a separate purchase;
- Possibility to connect the ST-65 GSM module - enables control of some control functions using a mobile phone (only and exclusively from DEFRO distribution) - optional for an additional charge;
- Possibility to connect the ST-505 Ethernet module or WIFI RS module - enables control of functions, parameter preview via the Internet (only from DEFRO distribution) - option available at an additional charge;
- Possibility to connect two additional valve control modules (only and exclusively from DEFRO distribution) - an option for an extra charge;
- Operation of the gearmotor with reverse operation;
- CH, DHW, valve, return, additional, exhaust gas and outside temperature sensor;
- Large, colorful graphic display;
- Touchpad;
- Adjustable screen tilt between 45 and 105 degrees
- Temperature protection (thermal);
- Screw temperature sensor;
- High quality housing;
- Has thermal boiler temperature protection - STB sensor;



K1P4

CONTROLLER FUNCTIONS:

- Innovative ADAPTIVE CONTROL control using a turbine flow meter ensuring optimal selection of fan and feeder operation parameters;
- Operation based on the PID control algorithm - calculation of the blow-in power based on the measurement of the boiler temperature and flue gas measured at the boiler outlet;
- Ability to export temperature history to an external USB memory;
- Possibility of cooperation with the exhaust fan module;
- Fan and screw feeder control;
- Mixing valve servo control as standard;
- weekly control;
- CH and DHW pump control;
- Control of two additional pumps;
- Preview of the amount of fuel in the container, based on user calibration;
- Cooperation with a room regulator with traditional (two-state) communication, eg ST-292v3 and equipped with RS communication, eg SPK Lux - works only with controllers from the DEFRO distribution company. Room regulators are a separate purchase;
- Possibility to connect the ST-65 GSM module - enables control of some control functions using a mobile phone (only and exclusively from DEFRO distribution) - optional for an additional charge;
- Possibility to connect the ST-505 Ethernet module or WIFI RS module - allows you to control functions, view parameters via the Internet (only from DEFRO distribution) - an option for an additional charge;
- Possibility to connect two additional valve control modules (only and exclusively from DEFRO distribution) - an option for an extra charge;
- Large, colorful graphic display;
- Touchpad;
- Adjustable screen tilt in the range of 45 to 105 degrees;
- Temperature protection (thermal);
- CH, DHW, valve, return, additional, exhaust gas and outside temperature sensor;
- Screw temperature sensor;
- High quality housing;
- Has thermal boiler temperature protection - STB sensor;

DEFRO CONTROLLERS



APC 3



APC K SLIM



ST 880ZPID

CONTROLLER FUNCTIONS:

- Innovative ADAPTIVE CONTROL control using a turbine flow meter ensuring optimal selection of fan and feeder operation parameters;
- Control of two igniters;
- Operation based on the PID control algorithm - calculation of the blow-in power based on the measurement of the boiler temperature and flue gas measured at the boiler outlet;
- External feeder control;
- Internal feeder control;
- Blower fan control;
- Exhaust fan control;
- Central heating pump control - C.O. ;
- Controlling the domestic hot water pump - DHW;
- Smooth control of mixing valves;
- Control of additional pumps (maximum two) with the possibility of choosing the type of device (central heating, domestic hot water pump, circulation, floor, break, short boiler cleaning);
- Buffer support;
- Preview of the amount of fuel in the container, based on user calibration;
- Minimum fuel level sensor;
- Software update via USB;
- Built-in module controlling two mixing valves;
- Weather control of the valve;
- weekly control;
- Cooperation with two room controllers with traditional (two-state) communication, eg ST-292v3 and with a controller equipped with RS communication, eg SPK Lux - works only with controllers from the DEFRO distribution. Room regulators are a separate purchase;
- Possibility to connect the ST-65 GSM module - enables control of some control functions using a mobile phone (only and exclusively from DEFRO distribution) - optional for an additional charge;
- Built-in Ethernet module - allows you to control functions, view parameters via the Internet;
- Possibility to connect two additional valve control modules (only and exclusively from DEFRO distribution) - an option for an extra charge;
- Photoresistor (flame sensor controlling the quality of the flame);
- Has thermal boiler temperature protection - STB sensor;
- Has a thermal burner protection;
- CH, DHW, valve, return, additional, exhaust gas and outside temperature sensor;

CONTROLLER FUNCTIONS:

- Innovative ADAPTIVE CONTROL control using a turbine flow meter ensuring optimal selection of fan and feeder operation parameters;
- Igniter control;
- Operation based on the PID control algorithm - calculation of the blow-in power based on the measurement of the boiler temperature and flue gas measured at the boiler outlet;
- External feeder control;
- Internal feeder control;
- Blower fan control;
- Control of the cleaning grate;
- Central heating pump control - C.O. ;
- Controlling the domestic hot water pump - DHW;
- Smooth control of the mixing valve;
- Controlling the additional pump with the possibility of choosing the type of device (central heating, domestic hot water pump, circulation, floor, overflow, boiler cleaning);
- Buffer support;
- Preview of the amount of fuel in the container, based on user calibration;
- Software update via USB;
- Built-in valve control module;
- Weather control of the valve;
- weekly control;
- Cooperation with a room regulator with traditional (two-state) communication, eg ST-292v3 and equipped with RS communication, eg SPK Lux - works only with controllers from the DEFRO distribution company. Room regulators are a separate purchase;
- Possibility to connect the ST-65 GSM module - enables control of some control functions using a mobile phone (only and exclusively from DEFRO distribution) - optional for an additional charge;
- Possibility to connect the ST-505 Ethernet module or WIFI RS module - allows you to control functions, view parameters via the Internet (only from DEFRO distribution) - an option for an additional charge;
- Possibility to connect two additional valve control modules (only and exclusively from DEFRO distribution) - an option for an extra charge;
- Possibility to connect an additional exhaust fan control module (only from DEFRO distribution) - optional for an additional charge;
- Photoresistor (flame sensor controlling the quality of the flame);
- Has thermal boiler temperature protection - STB sensor;
- Has a thermal burner protection;
- CH, DHW, valve, return, additional, exhaust gas and outside temperature sensor;

CONTROLLER FUNCTIONS:

- fan control;
- controlling the mixing valve actuator;
- central heating pump control;
- DHW pump control;
- additional pump control;
- Cooperation with a room regulator with traditional (two-state) communication, eg ST-292v3 or equipped with RS communication, eg SPK Lux - works only with controllers from the DEFRO distribution. Room regulators are a separate purchase;
- Possibility to connect the ST-65 GSM module - enables control of some control functions using a mobile phone (only and exclusively from DEFRO distribution) - optional for an additional charge;
- Possibility to connect the ST-505 Ethernet module - allows you to control functions, view parameters via the Internet (only from DEFRO distribution) - an option for an additional charge;
- Possibility to connect two additional valve control modules (only and exclusively from DEFRO distribution) - an option for an extra charge;
- Operation based on the PID control algorithm - calculation of the blow-in power based on the measurement of the boiler temperature and flue gas measured at the boiler outlet;

TIEMME CONTROLLER

CONTROLLER FUNCTIONS:

- Simple and intuitive control;
- Operation of the central heating pump;
- Automatic firing up process;
- Operation of a switching valve for domestic hot water heating;
- DHW heating mode;
- Possibility of cooperation with a room regulator or based on an external temperature sensor;
- Exhaust gas temperature sensor;
- Ambient probe;
- Removable connectors;
- Control panel with anti-static cover;
- Pellet level sensor support;

ROOM REGULATORS AND ADDITIONAL MODULES



RS COMMUNICATION SET

CONTROLLER FUNCTIONS:

ST-260 is a universal wireless set for equipped TECH controllers in RS communication. The set consists of two modules:

Module v1 - is intended for the main controller with RS communication. This module is intended for connection to a device with its own power supply

The v2 module - is intended for devices - additional modules with RS communication, e.g.: ST-280 room regulator, GSM communication module - ST-65, internet communication module - ST-505 etc.



GSM MODULE

CONTROLLER FUNCTIONS:

- control of sensor temperatures via sms messages;
 - sms notifications about boiler alarms;
 - the ability to change set temperatures using sms;
 - information on power failure;
 - module protection with an authorization code
- Additionally;
- possibility of connecting 2 sensors for temperature control;
 - connector detecting short / open contacts, eg for alarm connection;
 - input for connecting a contactor enabling remote control of any electrical circuit;

Controller equipment:

- Power Supply;
- RS communication cable to the boiler controller;
- GSM antenna;



DEFRO SPK LUX WIRELESS

CONTROLLER FUNCTIONS:

- temperature control of the central heating boiler;
- DHW temperature control;
- temperature control of mixing valves;
- room temperature control;
- view of the outside temperature;
- weekly heating program;
- alarm clock;
- parental lock;
- displaying current boiler and room temperature waveforms;
- displaying alarms occurring in the boiler main controller;
- large, readable, color touch screen;
- built-in room temperature sensor;
- ST-260 communication module for wireless communication;



INTERNET MODULE

CONTROLLER FUNCTIONS:

- remote control of boiler operation via the Internet;
- preview on all installation devices;
- the ability to edit all parameters of the main helm (while maintaining the structure) and menu order);
- preview of temperature history;
- viewing event history (alarms and parameter changes);
- the ability to assign any number of passwords (with different permissions - menus, events, statistics);
- editing the set temperature on the room regulator;
- the ability to support multiple modules from one administrative account;
- email notifications about alarms;
- optional SMS notification of alarms (subscription required);

Controller equipment:

- 9V DC power supply;
- RS tee;
- RS communication cable to the boiler controller;



WIFI MODULE

CONTROLLER FUNCTIONS:

- remote control of boiler operation via the Internet;
- preview on all installation devices;
- the ability to edit all parameters of the main helm (while maintaining the structure) and menu order);
- preview of temperature history;
- viewing event history (alarms and parameter changes);
- the ability to assign any number of passwords (with different permissions - menus, events, statistics);
- editing the set temperature on the room regulator;
- the ability to support multiple modules from one administrative account;
- email notifications about alarms;
- optional SMS notification of alarms (subscription required);

Controller equipment:

- 9V DC power supply;
- RS tee;
- RS communication cable to the boiler controller;

ROOM REGULATORS AND ADDITIONAL MODULES



I - 1

CONTROLLER FUNCTIONS:

- smooth control of a three or four-way valve;
- heating / cooling mode;
- pump control;
- the ability to control two other valves with additional i-1m, i-1 or ST-61v4 modules;
- the ability to connect the ST-505 internet module or WIFI RS - management via eModul;
- return temperature protection;
- weather and weekly control;
- cooperation with a room regulator with RS two-state communication;

Controller equipment:

- LCD display;
- boiler temperature sensor;
- valve temperature sensor;
- return temperature sensor;
- external weather sensor;
- construction adapted for assembly on the wall;



I - 1M

CONTROLLER FUNCTIONS:

- smooth control of a three or four-way valve;
- controlling the valve pump;
- cooperation with main controllers using RS communication;

Controller equipment:

- boiler temperature sensor;
- valve temperature sensor;
- return temperature sensor;
- external sensor;
- housing adapted for wall mounting;



ST-292 v3

CONTROLLER FUNCTIONS:

- two-state controller;
- room temperature control;
- weekly heating program;
- day / night program;
- manual program;
- OptimumStart function - selection of the optimal boiler activation time in order to achieve thermal comfort, so that the room is heated to the set temperature for a preset time;
- heating / cooling function;
- temporary display backlight;
- built-in room sensor;
- 3mm glass front panel;
- capacitive buttons;



ST-292 v2

CONTROLLER FUNCTIONS:

- two-state controller;
- room temperature control;
- weekly heating program;
- day / night program;
- manual program;
- OptimumStart function - selection of the optimal boiler activation time in order to achieve thermal comfort, so that the room is heated to the set temperature for a preset time;
- heating / cooling function;
- temporary display backlight;
- built-in room sensor;
- 3mm glass front panel;
- capacitive buttons;



DEFRO SPK LUX

CONTROLLER FUNCTIONS:

- temperature control of the central heating boiler;
- DHW temperature control;
- temperature control of mixing valves;
- room temperature control;
- view of the outside temperature;
- weekly heating program;
- alarm clock;
- parental lock;
- displaying current boiler and room temperature waveforms;
- displaying alarms occurring in the boiler main controller;
- large, readable, color touch screen;
- built-in room temperature sensor;
- RS communication cable to the boiler controller;



DISTRIBUTOR

www.en-defro.pl

Manufacturer: DEFRO R. Dziubela Spółka komandytowa
registered office: 26-067 Strawczyn, Ruda Strawczyńska 103A,
National Court Register: 0000620901, TIN: 9591968493, REGON: 363378898

tel. + 48 41 303 80 85, e-mail: biuro@defro.pl

Current prices of the products are available from the DEFRO authorized distributors or
in authorized points of sales. List of authorized points of sales is available at www.defro.pl.
The catalogue includes suggested retail prices.

Validity period: 03.01.2022 – 31.03.2022
EN 01/2022

